

Extruded chain guide profiles • Extruded product guide rails

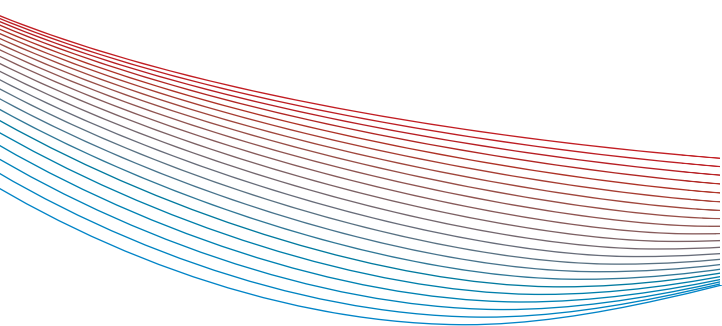

CONST**RUKTOR**
www.komponenty-maszyn.pl

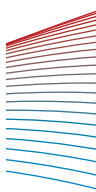

Profile ślizgowe

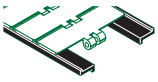

Extruded chain guide profiles

Our extruded chain guide profiles are the best alternative to metal guides for chain sliding in conveyor systems.

Usually, customers who use metal guides must lubricate them regularly so to obtain a silent sliding and to guarantee a long conveyor life. The plastic profiles, which are made of Polyethylene with ultra high molecular density (UHMWPE), preserve the chains and guarantee good sliding property and good wear resistance, and actually they offer:

- top sliding properties;
- top shock and breaking resistance;
- top chemical resistance;
- no humidity absorption;
- no corrosion;
- top antivibration property

These are the reasons why, the plastic extruded profiles in UHMWPE, are the best solution for chain sliding and can be used in many different industries such as: bottling, food, pharma, packaging, mechanics and so on.

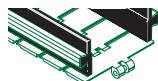
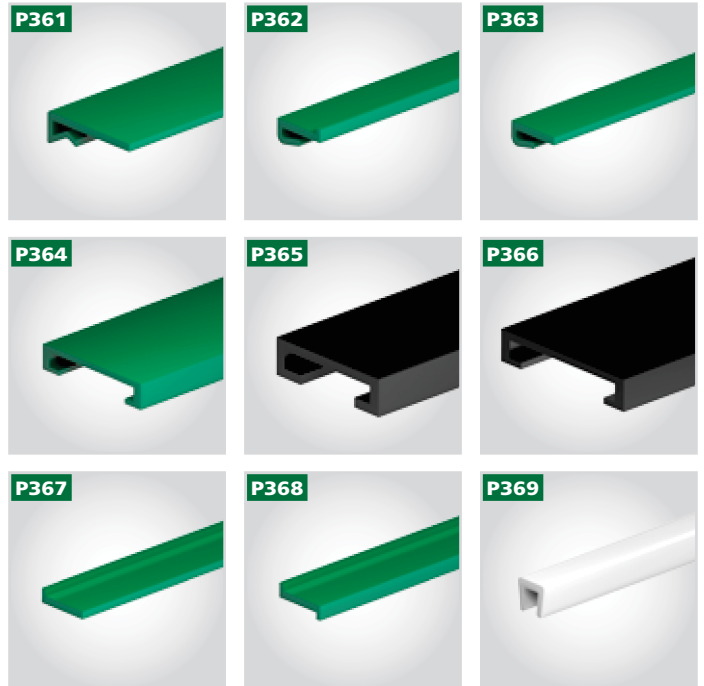
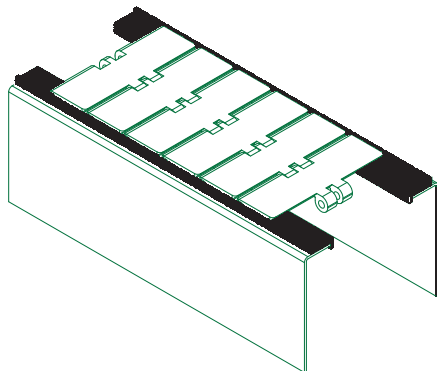

Extruded product guide rails

Our extruded product guide rails are made of Polyethylene with high molecular density (HMWPE), and therefore they have a low friction coefficient and a high chemical resistance. To ease the assembly operations and the replacement of the old items some guide rails are supplied with stainless steel AISI 304 profile already assembled (please see our part. 373, 353, 354) while some others are supplied without metal profile (please see our part. 370, 371, 372). Our product guide rails guarantee top sliding property and good wear resistance. Their use is suggested in many different industries such as: bottling, packaging, mechanics, food, pharma, ceramics, glass, paper etc.

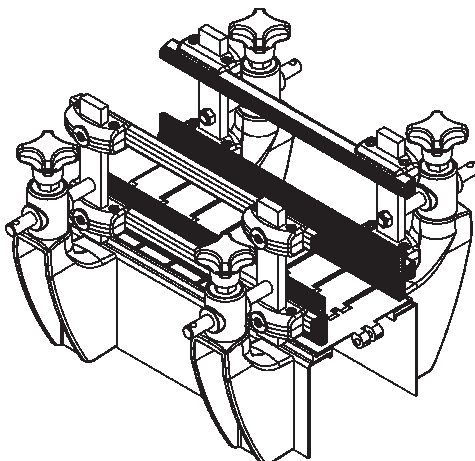

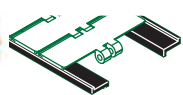

P361 - Extruded chain guide profiles supplied in coils of 50 Mt.

Materials: Extruded UHMWPE green colour.
Standard Packing: This item is sold in Mt. - min. 50 Mt.
On request:

- Guide profiles: Different colours and lengths.

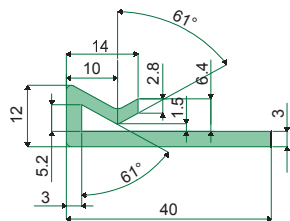

Code
361 / 83717

■ 50 Mt.



P362 - Extruded chain guide profiles supplied in coils of 50 Mt.

Materials: Extruded UHMWPE green colour.
Standard Packing: This item is sold in Mt. - min. 50 Mt.
On request:

- Guide profiles: Different colours and lengths.

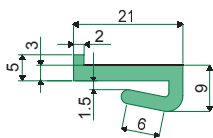

Code
362 / 83718

■ 50 Mt.



P363 - Extruded chain guide profiles supplied in coils of 50 Mt.

Materials: Extruded UHMWPE green colour.
Standard Packing: This item is sold in Mt. - min. 50 Mt.
On request:

- Guide profiles: Different colours and lengths.

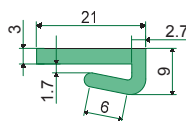

Code
363 / 83719

■ 50 Mt.



P364 - Extruded chain guide profiles for flat 30x3 mm. supplied in 3 Mt. lengths

Materials: Extruded UHMWPE green colour.
Standard Packing: This item is sold in Mt. - min. 6 Mt. (2 lengths).
On request:

- Guide profiles: Different colours and lengths.

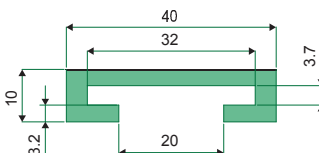

Code
364 / 83720

■ 3 Mt.



P365 - Extruded chain guide profiles for flat 40x6 mm. supplied in 6 Mt. lengths

Materials: Extruded UHMWPE black colour.
Standard Packing: This item is sold in Mt. - min. 12 Mt. (2 lengths).
On request:

- Guide profiles: Different colours and lengths.

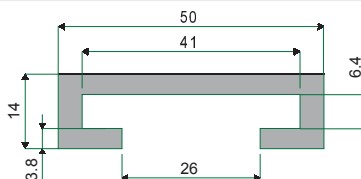

Code
365 / 83721

■ 6 Mt.



P366 - Extruded chain guide profiles for flat 50x6 mm. supplied in 6 Mt. lengths

Materials: Extruded UHMWPE black colour.
Standard Packing: This item is sold in Mt. - min. 12 Mt. (2 lengths).
On request:

- Guide profiles: Different colours and lengths.

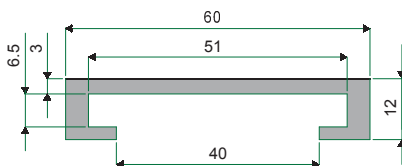

Code
366 / 83722

■ 6 Mt.



P367 - Extruded chain guide profiles supplied in coils of 50 Mt.

Materials: Extruded UHMWPE green colour.
Standard Packing: This item is sold in Mt. - min. 50 Mt.
On request:

- Guide profiles: Different colours and lengths.

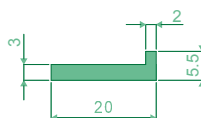

Code
367 / 83723

■ 50 Mt.



P368 - Extruded chain guide profiles supplied in coils of 50 Mt.

Materials: Extruded UHMWPE green colour.
Standard Packing: This item is sold in Mt. - min. 50 Mt.
On request:

- Guide profiles: Different colours and lengths.

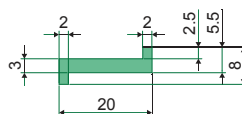

Code
368 / 83724

■ 50 Mt.



P369 - Extruded chain guide profiles supplied in coils of 50 Mt.

Materials: Extruded UHMWPE white colour.
Standard Packing: This item is sold in Mt. - min. 50 Mt.
On request:

- Guide profiles: Different colours and lengths.

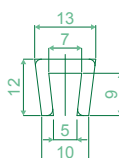

Code
369 / 83725

□ 50 Mt.



P370 - Extruded product guide rails in coils of 50 Mt.

Materials: Extruded HMWPE white colour.
Standard Packing: This item is sold in Mt. - min. 50 Mt.
On request:

- Guide rails: Different colours and lengths.

Code
370 / 83726

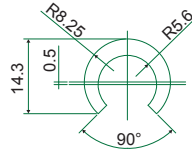

50 Mt.



P371 - Extruded product guide rails in coils of 50 Mt.

Materials: Extruded HMWPE white colour.
Standard Packing: This item is sold in Mt. - min. 50 Mt.
On request:

- Guide rails: Different colours and lengths.

Code
371 / 83727

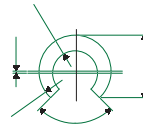

50 Mt.



P372 - Extruded product guide rails in 6 Mt. lengths

Materials: Extruded HMWPE green colour.
Standard Packing: This item is sold in Mt. - min. 12 Mt. (2 lengths).
On request:

- Guide rails: Different colours and lengths.

Code
372 / 83728

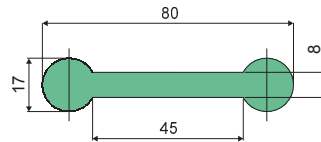

6 Mt.



P373 - Extruded product guide rails in 3-6 Mt. lengths

Materials: Extruded HMWPE green colour, metal profile in stainless steel AISI 304 or zinc plated.
Standard Packing:

- 3 Mt. lengths version: This item is sold in Mt. - min. 6 Mt. (2 lengths);
- 6 Mt. lengths version: This item is sold in Mt. - min. 12 Mt. (2 lengths).

On request:

- Guide rails: Different colours and lengths.

Metal profile in zinc plated steel	Metal profile in stainless steel AISI 304	Length
Code	Code	
373 / 83732	373 / 83733	3 Mt.
373 / 83734	373 / 83735	6 Mt.

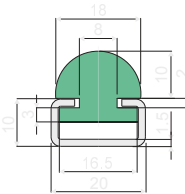

3 Mt.
 6 Mt.



P353 - Extruded product guide rails in 6 Mt. lengths

Materials: Extruded HMWPE white colour, metal profile in stainless steel AISI 304.
Standard Packing: This item is sold in Mt. - min. 12 Mt. (2 lengths).
On request:

- Guide rails: Different colours and lengths.

Code
353 / 83441

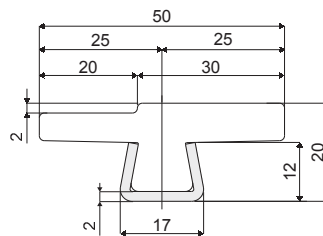

6 Mt.



P354 - Extruded product guide rails in 3-6 Mt. lengths

Materials: Extruded HMWPE white colour, metal profile in stainless steel AISI 304.
Standard Packing:

- 3 Mt. lengths version: This item is sold in Mt. - min. 6 Mt. (2 lengths);
- 6 Mt. lengths version: This item is sold in Mt. - min. 12 Mt. (2 lengths).

On request:

- Guide rails: Different colours and lengths.

Code	Length
354 / 83626	3 Mt.
354 / 83442	6 Mt.

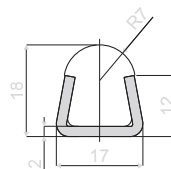

3 Mt.
 6 Mt.



	Unit	UHMWPE	HMWPE
DIN denomination	-	UHMWPE	HMWPE
Specific weight	Kg/dm ³	0,95	0,95
Humidity absorption	%	< 0,1	< 0,1
Inflammability according to UL 94	-	HB	HB
Melting temperature	°C	135	129
Short use temperature	°C	90	90
Long use temperature	°C	-200 / +80	-100 / +80
Thermic conductivity	W/K*m	0,42	0,43
Specific heat capacity	J/g*K	1,84	1,88
Coefficient of linear thermal expansion	1,E-6/K	20	20
Elongation at break	%	> 350	> 700
Elastic modulus at traction	N/mm ²	-	1100
Elastic modulus at bending	N/mm ²	750	1000
Resistance test with notched sample	KJ/m ²	200	130
Durometer hardness	N/mm ²	38	40
Friction coefficient in dry environment	-	0,12	0,25
Wear at trail	µM/Km	0,45	1
Dielectric constant	-	2,3	2,3
Dielectric-loss factor	-	-	-
Surface resistance	Ω	1,E + 14	1,E + 14
Specific mass resistance	Ω*cm	1,E + 16	1,E + 17
Electric rigidity	KV/mm	90	90



CONSTRUKTOR
www.komponenty-maszyn.pl

